

A-360

SiRFstarIII™ GPS Module



Introduction

A-360 GPS Module consists of SiRFstarIII™ technology. (INTERNAL 4Mbit FLASH)
A-360 contains LNA, SAW Filter, Reset IC, RTC X-tal, TCXO and Regulator.

Product Features

- * Fully self-contained GPS receiver.
- * Fully shield.
- * Full implement of SiRFstarIII™ GPS architecture.

- GSP3f (GPS Engine with integrated Processor and Flash)
- GRF3w (A Highly Integrated GPS RF)
- Low noise amplifier
- SAW filter
- TCXO
- 32.768KHz RTC X-tal
- Reset & Regulator, etc.
- Fast time-to-first-fix

Product applications

- Automotive applications

- Personal positioning and navigation
- Mobile and PDA applications, etc

Technique specifications

Receiver type: L1 frequency, C/A Code, 20-channel

Max up-date rate: 1Hz

Accuracy (SA off): Position < 10M 2DRMS

Tracking Sensitivity: -159dBm (at the receiver input)

Operational Limits: Altitude < 18,000m (60,000ft) velocity < 515m/s (1,000knots)

Time to First Fix (TTFF)

a) Cold start 60sec (typical)

In Cold start scenario, the receiver has no knowledge on last position, approximate time or satellite constellation. The receiver starts to search for signals blindly. Cold start time is the longest startup time for SiRFstarIII™.

b) Warm start 38sec (typical)

In Warm Start scenario, the receiver knows -due to a backup battery- his last position, approximate time and almanac. Thanks to this it can quickly acquire satellites and get a position fix faster than in cold start mode.

c) Hot start < 8sec (typical)

In Hot Start scenario, the receiver was off for less than 2 hours. It uses its last Ephemeris data to calculate a position fix.

Re-acquisition Time 3sec. typical (within 5sec. Block out)

5sec. typical (within 60sec block out)

Protocol NMEA 0183 (Default) activated message: GLL, GGA, RMC, VTG, GSV, GSA all with checksum enabled SiRF Binary

Size 70.15mm x 40.6mm x 14.1mm

Mechanical Layout

1) DIMENSION

PCB Layout

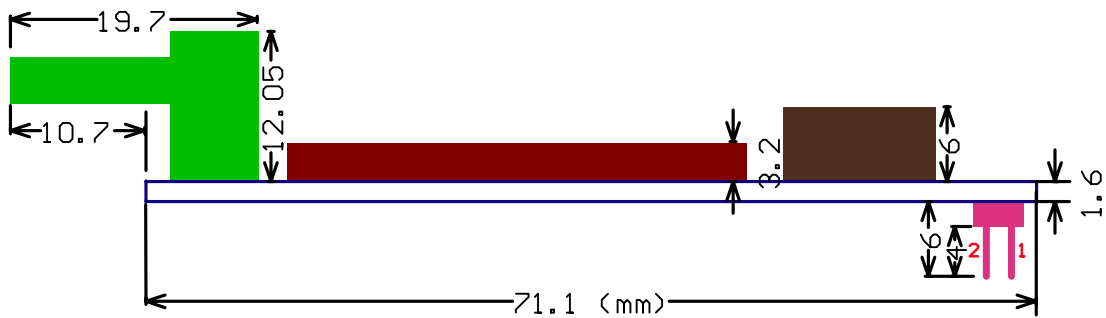
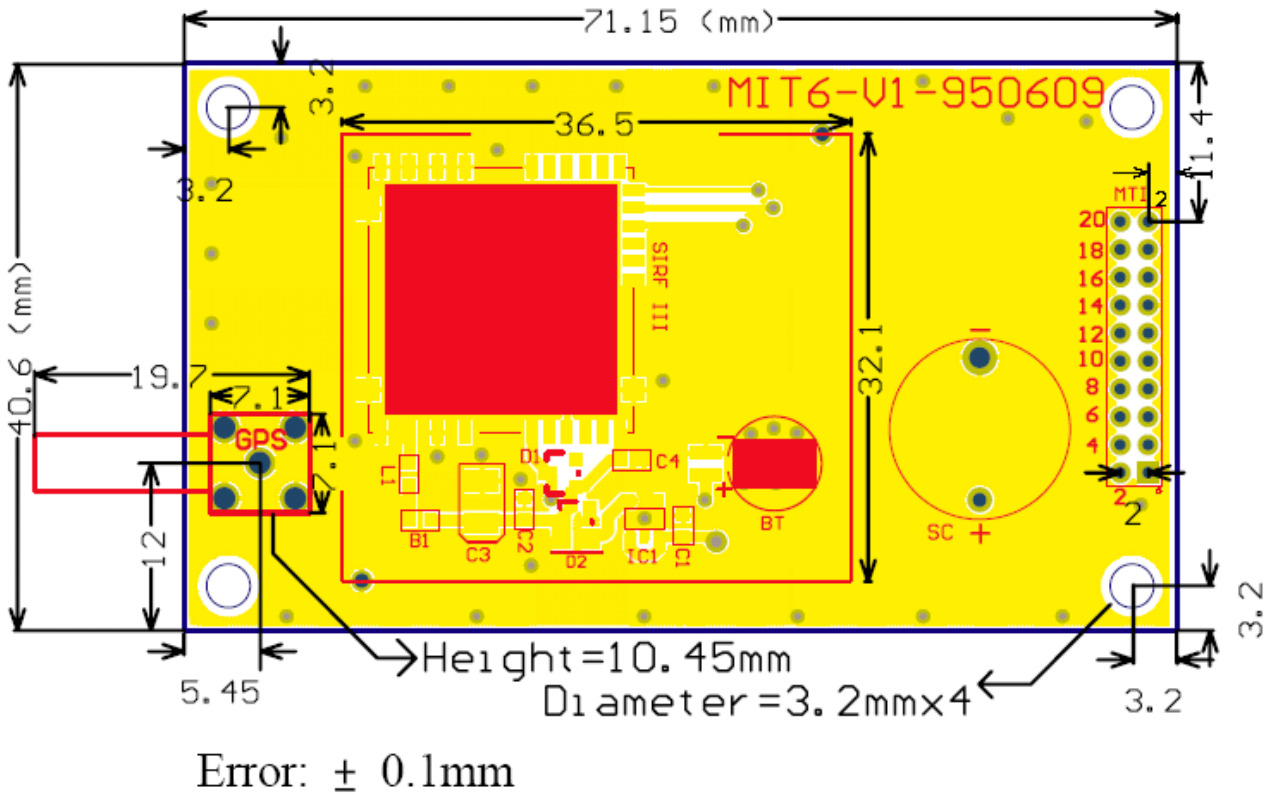

Hardware interface

*** Pin-out of the 20-pin interface connector**

Pin Number	Name	Description	Type
1	NC	(No Used)	Input
2	VDC	3.8V~6.5V DC Power Input	Input
3	NC	(No Used)	
4	VDC	(Shorted with pin 2)	Input
5	Reset	Reset Input (Active Low)	Input
6	TIME	1pps timemark output	I/O
7	NC	(No Used)	
8	NC	(No Used)	
9	NC	(No Used)	
10	GND	Ground	
11	TXA	Serial Data Output A (GPS Data)	Output
12	RXA	Serial Data Input A (Command)	Input
13	GND	Ground	
14	NC	(No Used)	
15	NC	(No Used)	
16	GND	Ground	
17	NC	(No Used)	
18	GND	Ground	
19	NC	(No Used)	

20	NC	(No Used)	
----	----	-----------	--

RESET

An external reset is initiated by pulling RESET low for at least 1 μ s. If not used, RESET can be left unconnected since there is an internal 10k pull-up resistor.

RESET is also used in Push-to-Fix mode in order to wake up the unit and request a position fix. Minimum pulse width is 1 μ s.

RF IN

The line on the PCB from the antenna (or antenna connector) has to be a controlled impedance line (Microstrip at 50 Ω). 3.3V

VBAT

This is the battery backup supply that powers the SRAM and RTC when power is removed. Without an external backup battery or on board battery, engine board will execute a cold start after every turn on. To achieve the faster start-up offered by a hot or warm start, either a backup battery must be connected or battery installed on board.

Serial Interface

The A-360 GPS receivers provide two serial ports. All serial interface signals (operate on 3.3V CMOS)

Baud Rate	Comments
1200	NMEA,suitable for RMC message only
2400	NMEA,suitable for RMC message only
4800	Must deactivate some messages to avoid communication bottleneck and loss of information,e.g.NMEA:RMC and ZDA only
9600	Minimum recommended baud rate for NMEA output in standard Configuration
19200	Minimum recommended baud rate for SiRF Binary Protocol output
38400	Minimum recommended baud rate for SiRF Binary Protocol output including development data and raw tracking data.
57600	Minimum recommended baud rate for SiRF Binary Protocol output including development data and raw tracking data.

Electrical Specification

Absolute Maximum Ratings

Parameter	Min	Max	Unit
Power supply voltage(VDD,V_BAT)	-0.3	4.8	V
Serial port Input pin voltage	-0.3	5.0	V
I/O port voltage	-0.3	VCC+0.3	V
I/O port current		±25	mA
Storage temperature	-65	150	°C

Warning – Stressing the device beyond the “Absolute Maximum Ratings” may cause permanent damage. These are stress ratings only. Operation beyond “Operating conditions” is not recommended and extended exposure beyond the “Operating condition” may affect device reliability. This module is not protected against over voltage, reversed voltage or short current of RF_IN port.

Operating Conditions

(Test Temperature : 25)

Parameter	Condition	Min	Typ	Max	Unit
Operating supply voltage	VCC	2.7	3.3	3.6	V
Operating supply ripple voltage				50	mV
Backup battery input voltage	V_BAT	1.9		3.6	V
I/O input low level				0.3xVCC	V
I/O input high level		0.7xVCC			V
I/O output high level	Ioh=2mA	2.4	2.8		V
I/O output low level	Iol=2mA		0.2	0.4	V
Antenna input voltage	V_ANT	2.7	3.3	5.0	V
Sustained supply current	VCC=3.3V		80		mA
Peak supply current	VCC=3.3V		100		mA
Operating temperature	VCC=3.3V	-40	25	+85	°C

Appendix A: Reference Design

Backup Battery reference design :
 (rechargeable Lithium battery)

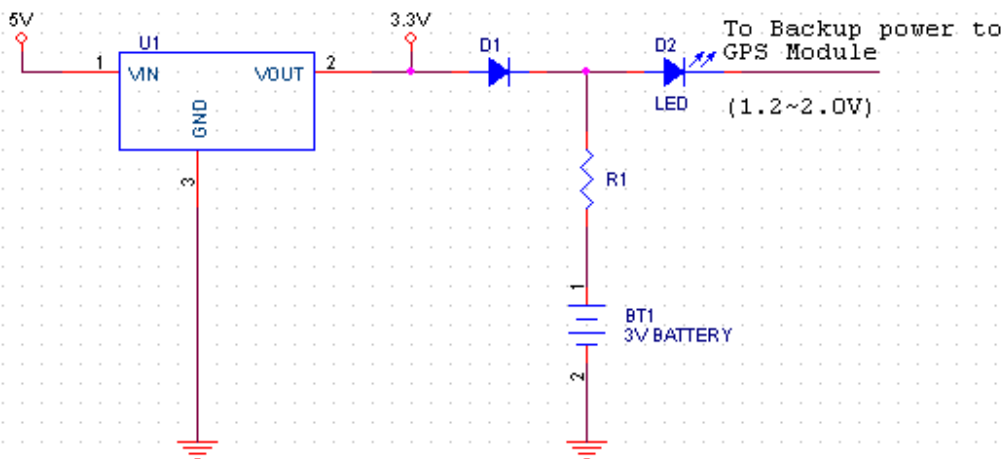

U1 constant voltage element
 D1 select a shotkey diode of small inverse current
 R1 selected depend on charge voltage of battery

for example :

U1 : RT9167-33CB (RICHTEK)
 D1 : BAT54 (FAIRCHILD)
 R1 : 100 Ohm
 D2 : LED
 Battery : ML414S (Panasonic)

Backup Battery reference design :
(rechargeable Nimh battery)

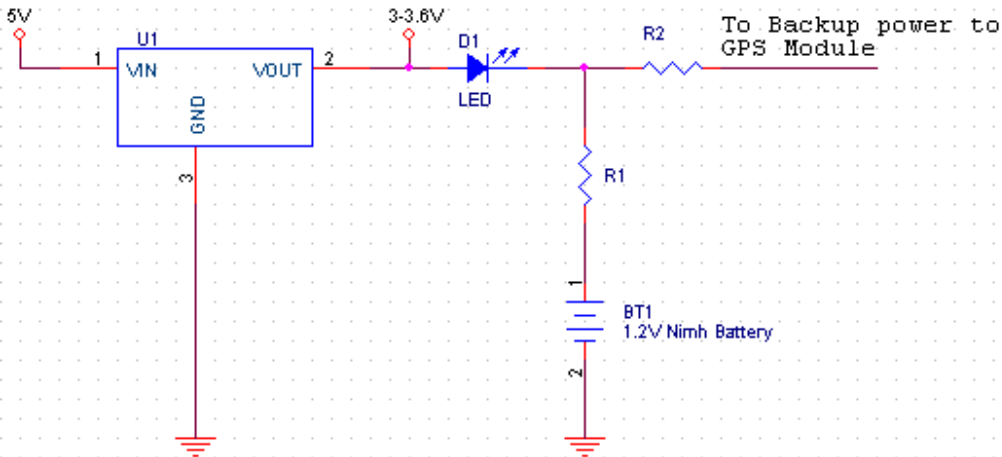

U1 constant voltage element
D1 select a led to drop voltage
R1& R2 selected depend on charge voltage of battery
Wonde-X Charging rate (0.05C-0.1C)

for example :
U1 : RT9167-33CB (RICHTEK)
D1 : LED
Battery : 1.2V Nimh Battery